

H.323

- H.323 is a standard of the International Telecommunications Union-Telecommunications Standardization (ITU-T)
- Currently it is a widely adopted signalling suite for VoIP services
- The first release of H.323 dates back to year 1996

H.323

- H.323 is the specification of a complete network architecture
- H.323 is a wide standard which includes a large number of documents
- The basic standard documents referred in this presentation are H.255.0 and H.245

Architecture

- The H.323 architecture includes
 - terminals
 - Multipoint Controller Units
 - gatekeepers
 - gateways
- The basic objective of H.323 is
 - To enable the exchange of media streams among endpoints, in a switched fashion

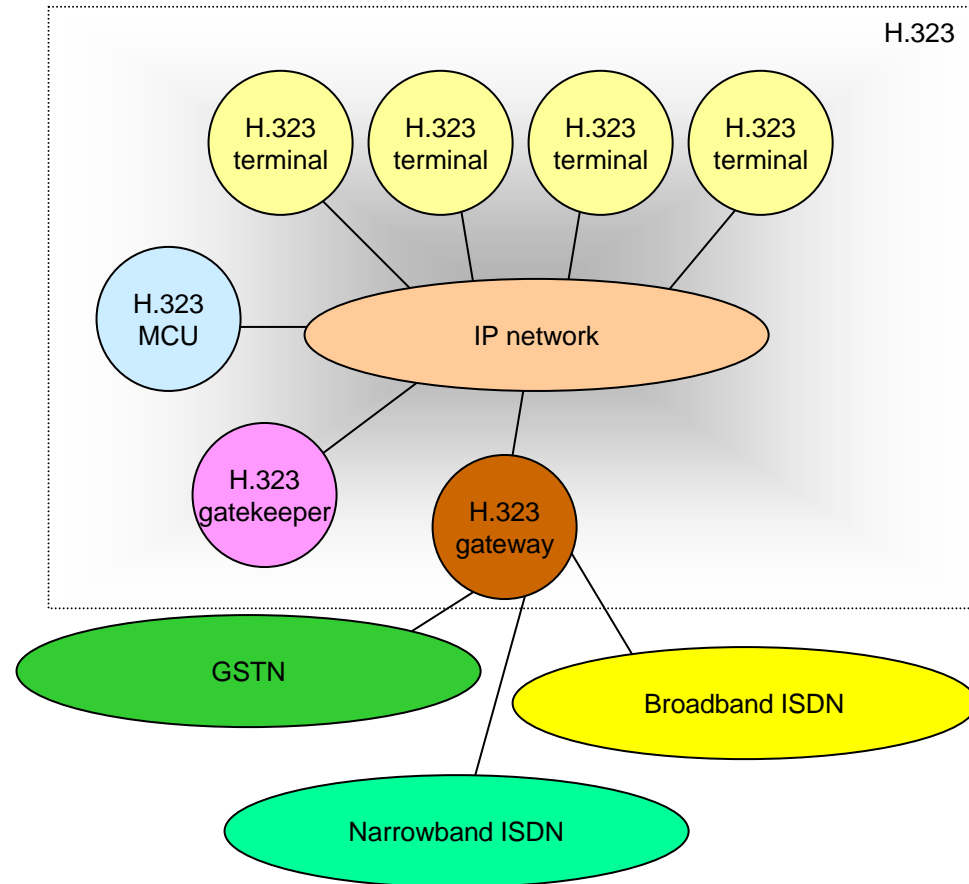

Architecture

- Usually, the terminal is the user's equipment
- The terminal must support at least one coded, but in general it supports multiple codecs
- The terminal can also implement a video codec

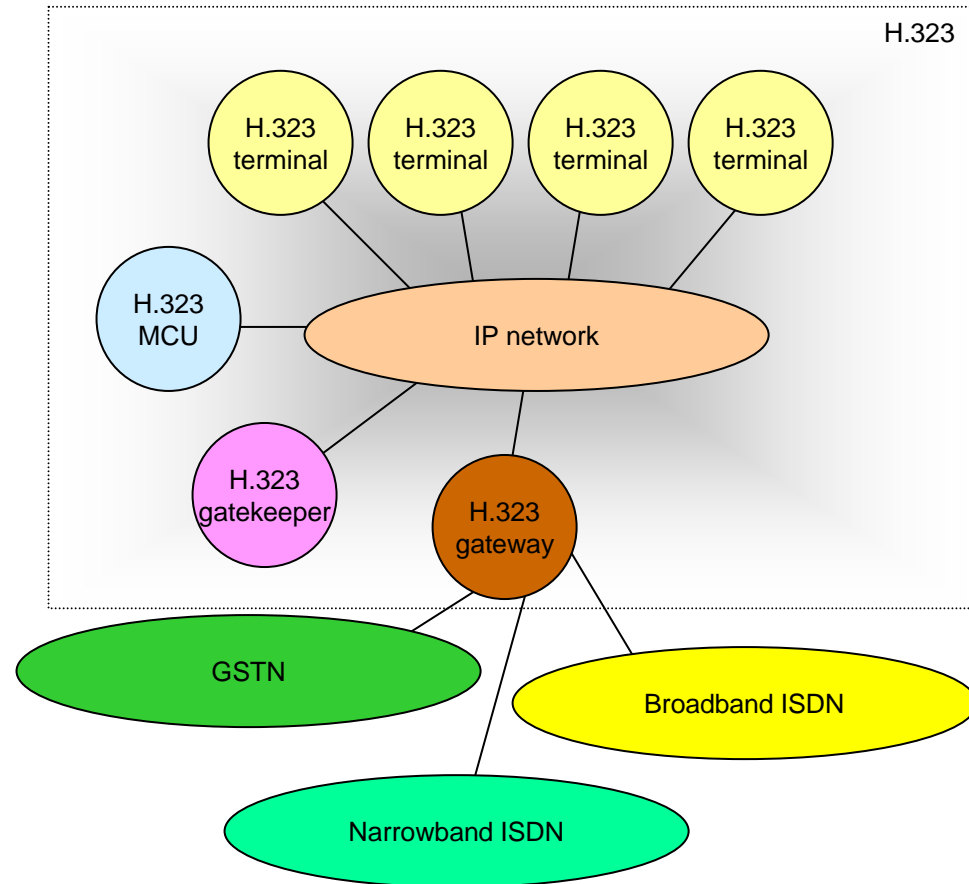

Architecture

- The gateway translates signalling to external (and also different) signaling domains
- External networks interfaced by a gateway can be GSTNs (Generalized Switched Telephone Networks) including both fixed and mobile networks

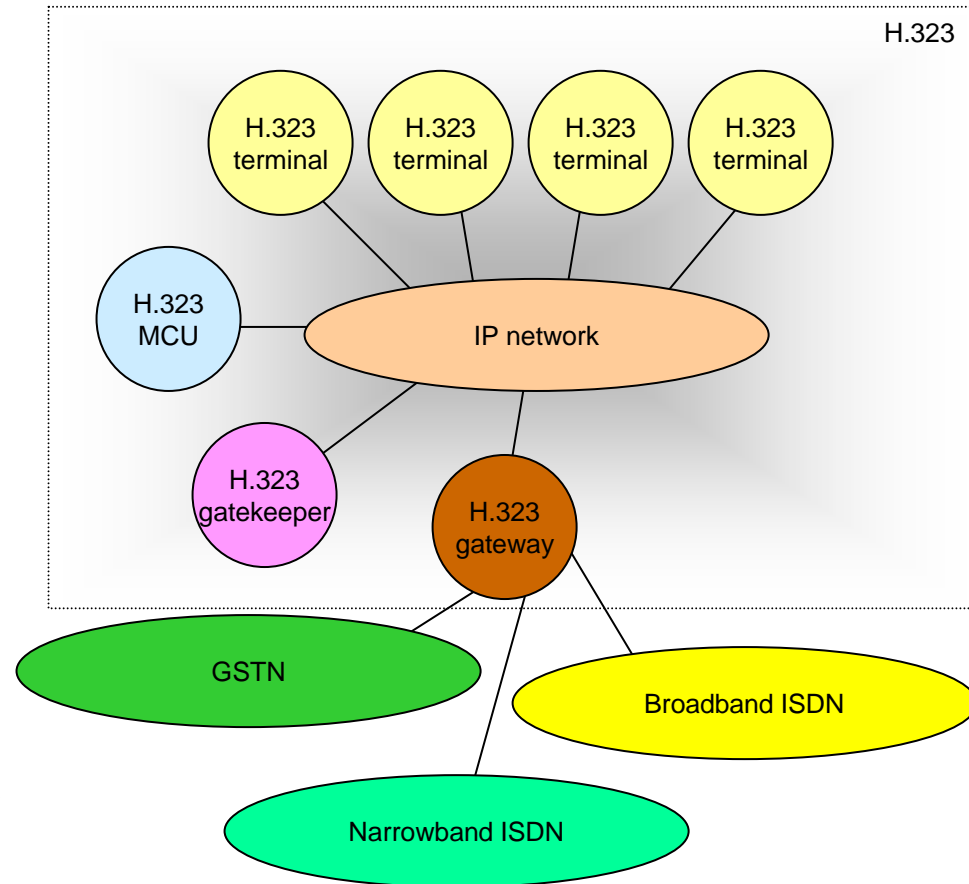

Architecture

- On one side, the gateway supports H.323 signaling
- On the side interfacing to an external network, it supports the remote signalling system (for example, SS7 for a PSTN)

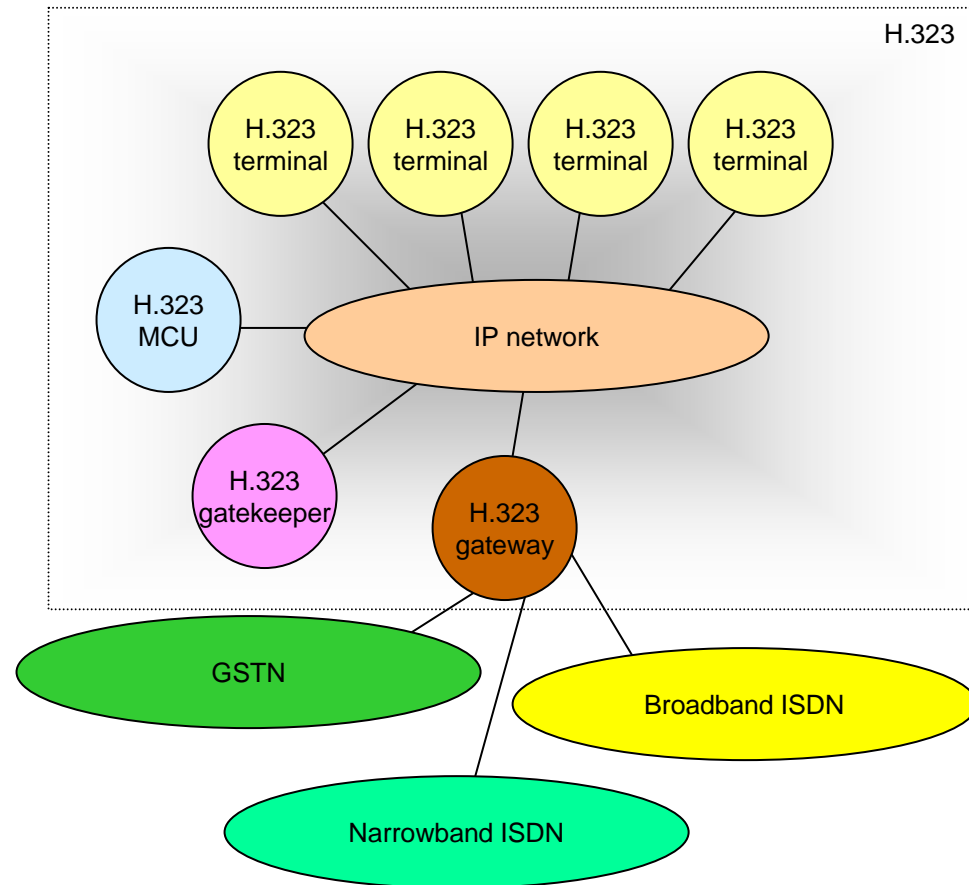

Architecture

- On the user plane, the translation service provided by the gateway implements codec translation
- On the control plane, it interworks different signaling systems
- As shown in the picture, through H.323 gateways it is possible to interconnect separate h.323 networks through another type of network

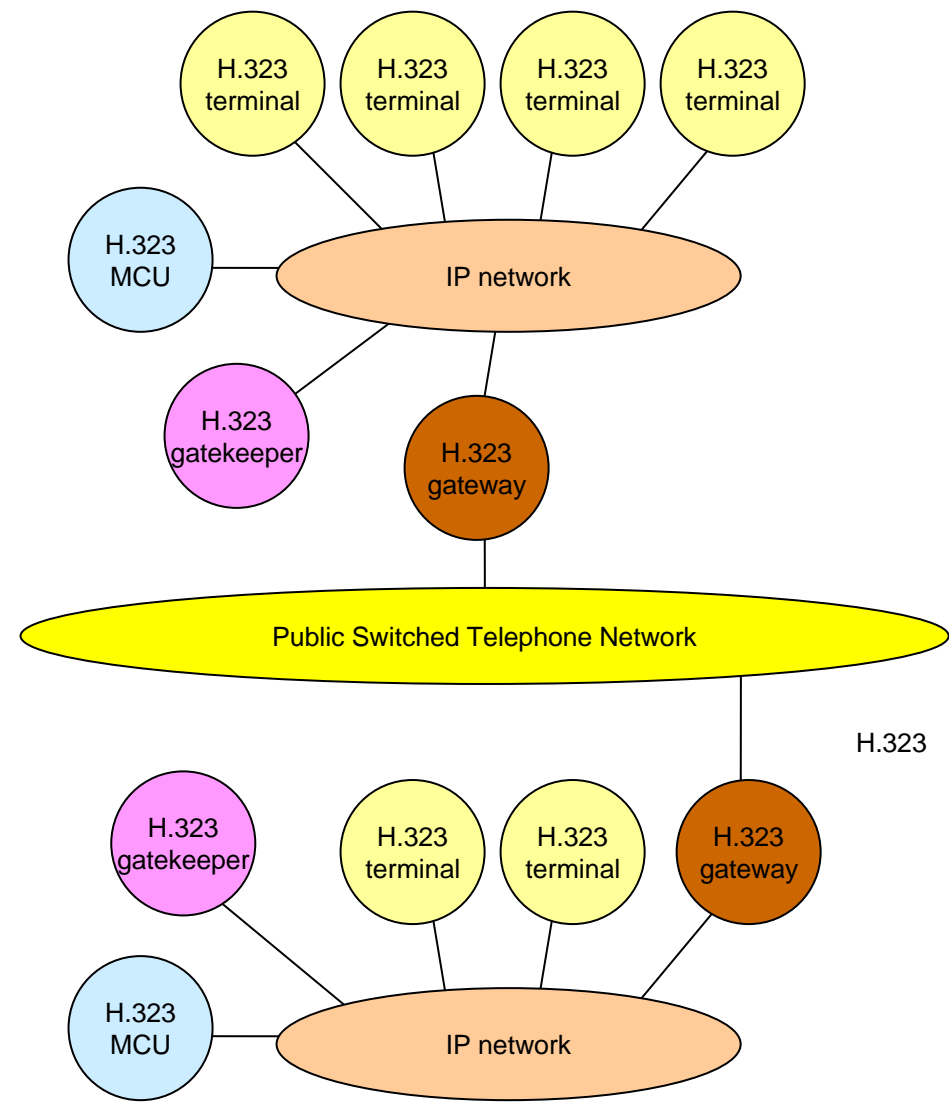

Architecture

- The H.323 gatekeeper is optional, but in most network a number of gatekeeper is always present
- The gatekeeper controls a number of devices (terminals, MCUs, gateways)
- The control performed by the gatekeeper includes acceptance of devices into the network and authorization to perform basic tasks such as call set up
- The gatekeeper allows for a strict control of the H.323 network
- The gatekeeper can also perform bandwidth control and in this way it can interconnect with signaling system for the control of the Quality of Service

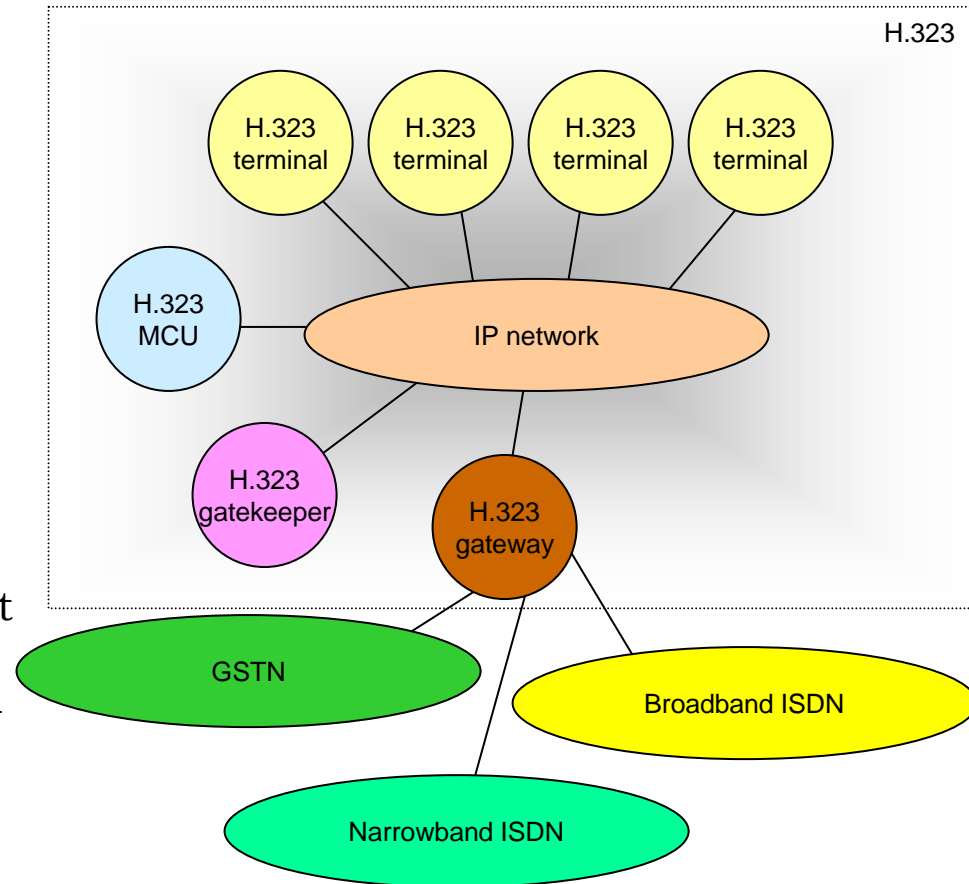

Architecture

- A set of devices controlled by a gatekeeper is called a *zone*
- In the figure, a two-zone network is shown
- The division of a network into zones is a way to achieve scalability, as each gatekeeper must control a limited number of devices

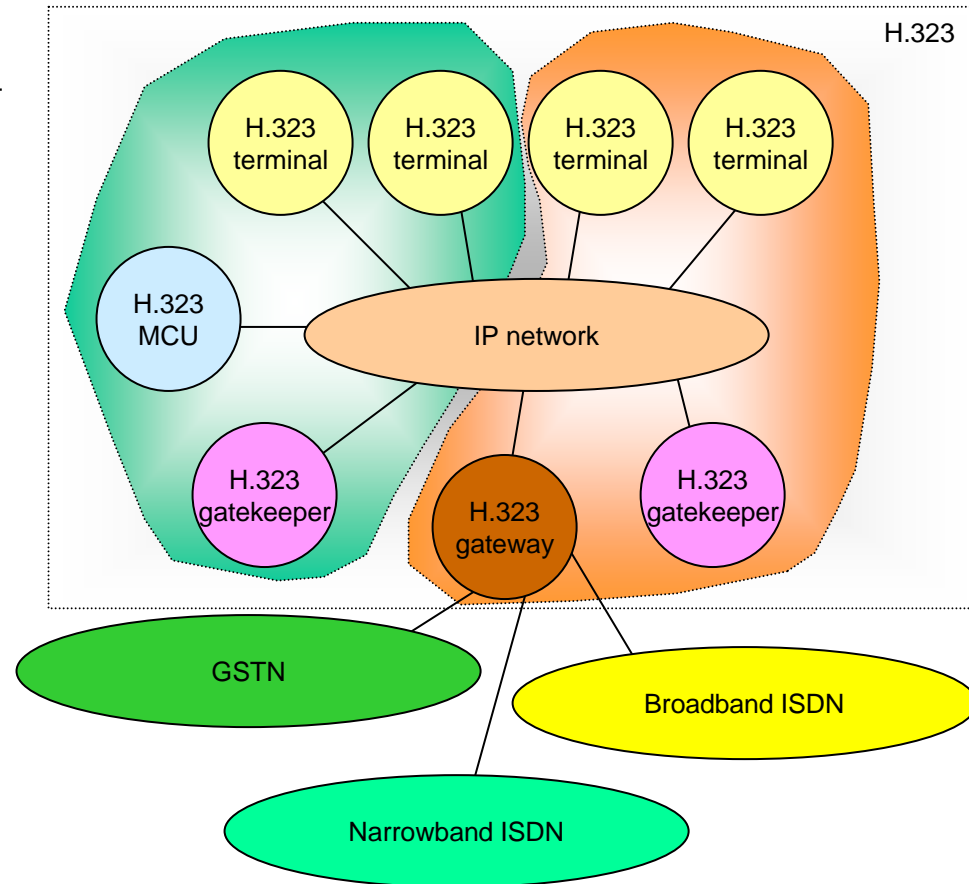

Architecture

- Un MC e' il Multipoint Controller
- Gestisce chiamate in conferenza tra molteplici terminali/gateway
- Il MC stabilisce quale formato di media va utilizzato (si deve avere compatibilita' mutua tra i partecipanti)
- Cio' avviene trasmettendo ai partecipanti un *capability set*
- Il *capability set* puo' essere cambiato dinamicamente dal MC in seguito a join/leave durante la conferenza

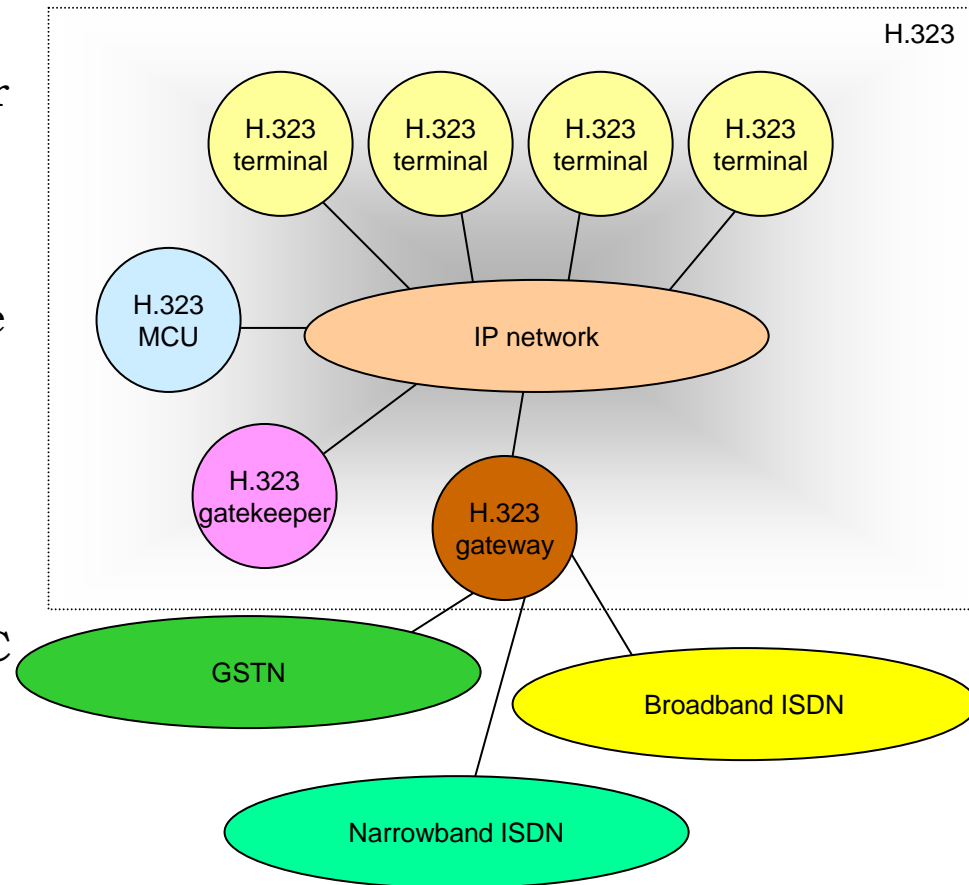

H.323 protocols

- H.323 call signaling and control signaling are derived from the former ITU specifications of the ISDN Q.931 suite
- H.225.0 is the RAS signaling, where RAS means Registration, Admission and Status
- RAS signaling is the communication protocols among devices and the gatekeeper in a zone of the H.323 network

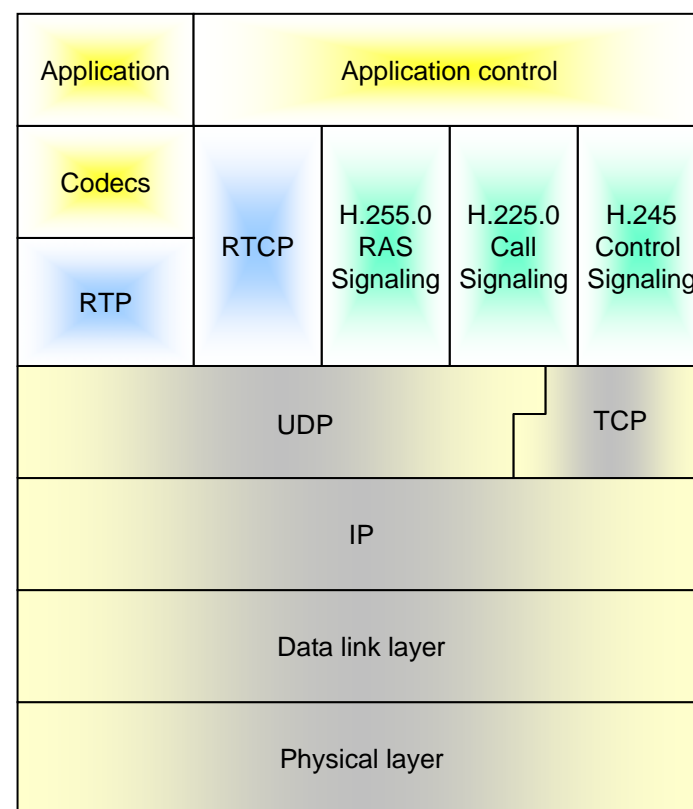

H.323 protocols

- For example, a terminal must use RAS to register itself at its gatekeeper and join the network
- RAS signaling uses UDP as a transport protocol
- Call signaling can be carried by both UDP and TCP
- Old version of H.323 before version 4 use UDP for call signaling
- Starting from version 4, both TCP and UDP can be used

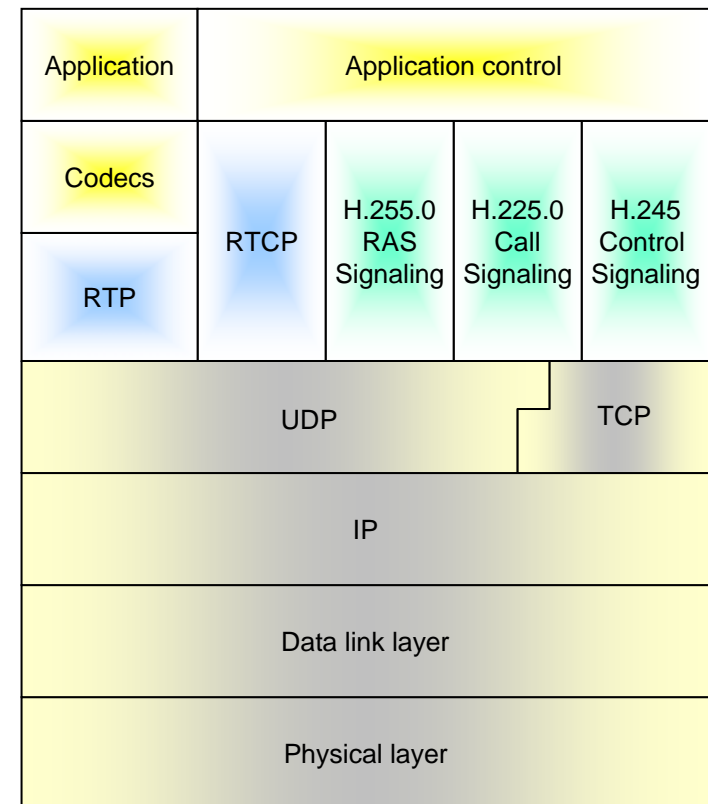

H.323 protocols

- Control signaling H.245 is used for communication between the endpoints of a connection
- H.245 has the purpose of allowing the negotiation of media formats
- H.245 establishes the logical channels through which codec negotiation is to be carried out
- Through codec negotiation, the endpoints of a connection determine which codec is to be used for the connection

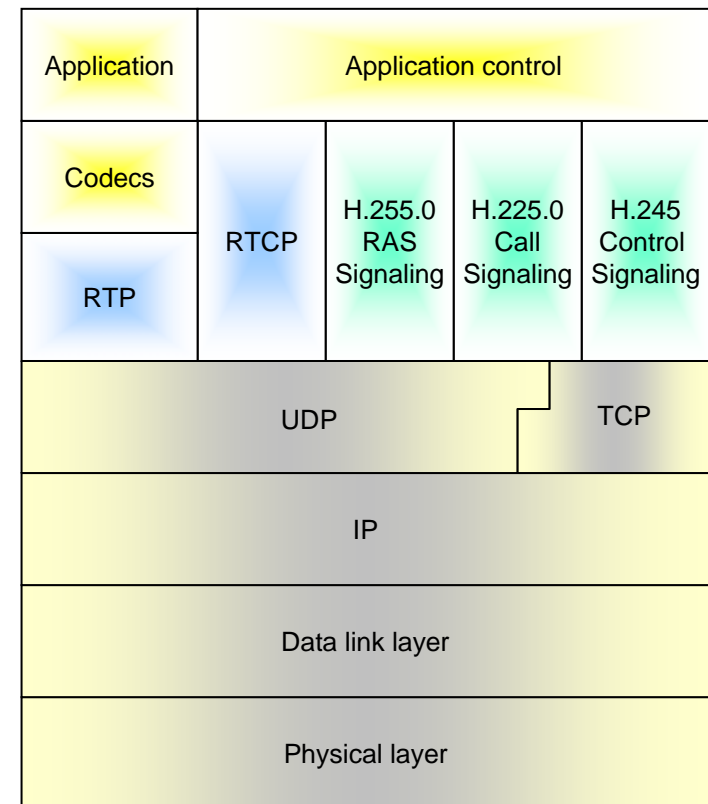

H.323 protocols

- In general, in order to establish a connection all the three described forms of signaling are used
- For each signalling category a logical channel is established
- A logical channel is a specific pair of sockets

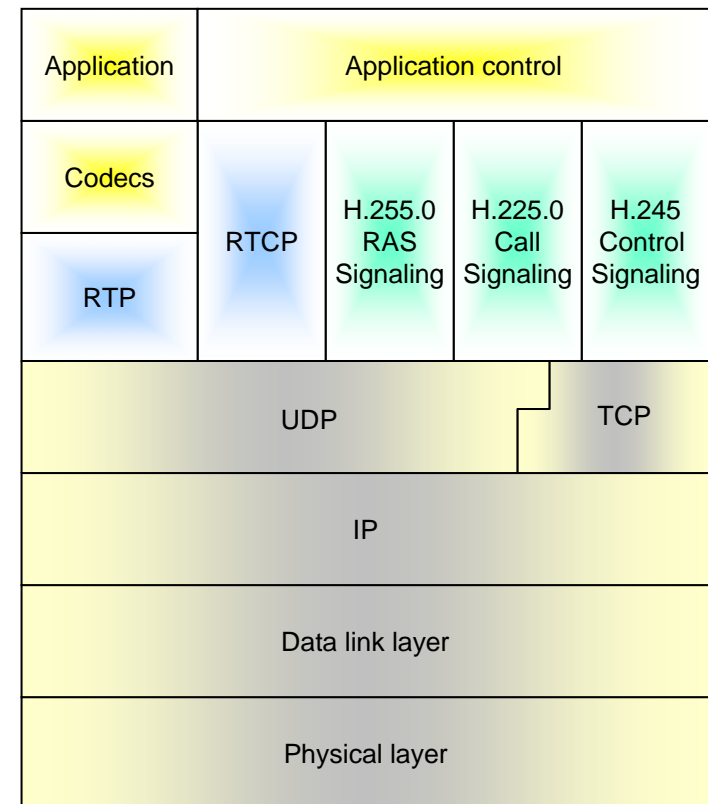

Audio and video codecs

- H.323 devices must support a basic set of codecs, such as G.711 both in A-law and in μ -law fashion
- Usually multiple codecs are supported, including compressed codecs such as G.729
- For video media streams, H.323 devices must support at least the H.261 Quarter Common Intermediate Format (QCIF)

RAS signaling

- RAS is the signaling exchanges between a gatekeeper and a devices it controls
- RAS signaling is the means by which a gatekeeper controls its zone
- RAS signaling supports a large number of functions, among which:
 - Gatekeeper discovery
 - By which a device discovers its gatekeeper
 - Registration/Unregistration
 - With the gatekeeper

RAS signaling

- Admission
 - An endpoint asks to the gatekeeper the authorization to participate to a call; bandwidth may be specified
- Bandwidth change
 - Function by which, for example, the gatekeeper can force an endpoint to reduce the consumed bandwidth
- Disengage
 - Used by the endpoint to communicate to the gatekeeper that it is leaving a connection
- Status
 - Messages exchanged to communicate information about the status of a device
- Resource availability
 - A device can communicate to a gatekeeper the amount of free resources available

Gatekeeper Discovery

- In order to register, an endpoint must first discover its gatekeeper
- The endpoint may have been configured statically with the address of a gatekeeper: no discovery is needed in this case; however, this solution is not flexible
- In order to perform discovery, the endpoint sends a Gateway-Request message (GRQ) to
 - A set of preconfigured IP addresses or
 - To the IP multicast group 224.0.1.41:1718

Gatekeeper discovery

- A gatekeeper can answer with a Gatekeeper ConFirmation message (GCF) or Gatekeeper ReJect message (GRJ)
- A gatekeeper can also respond with a GCF message including an alternative list of gatekeepers to be checked by the terminal
- If the endpoint received multiple positive answers, it chooses one

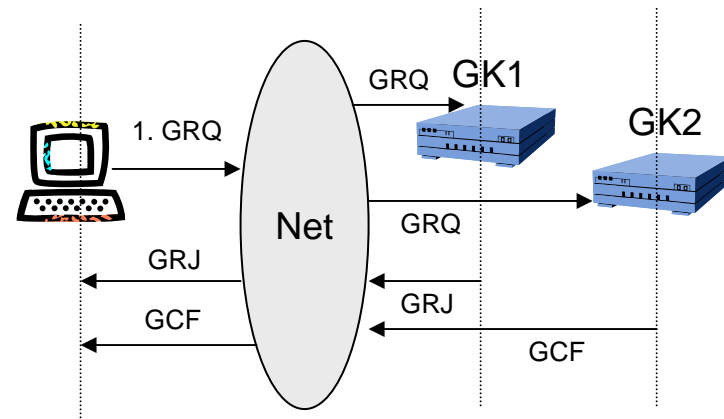

Endpoint registration and cancellation

- The endpoint sends to the gatekeeper the Registration ReQuest (RRQ) message, on the RAS port (1719)
- The gatekeeper can accept the request by replying with a Registration ConFirmation, RCF, message or reject the request with a Registration ReJect, RRJ, message
- Registrations have a limited duration, explicitly stated in seconds, up to a maximum of 136 years (usually they are shorter than the maximum)
- If a registration is going to expire soon, the endpoint can renew it with another RRQ message, with the Keepalive option activated
- Endpoint unregistration is implemented through Unregistration ReQuest (URQ) messages and the associated positive response is Unregistration ConFirmation (UCF)
- If the unregistration request is placed while a connection involving the requesting terminal is active, the request is rejected with a Unregistration ReJect (URJ) message
- The gatekeeper can autonomously unregister a terminal

Endpoint registration and cancellation

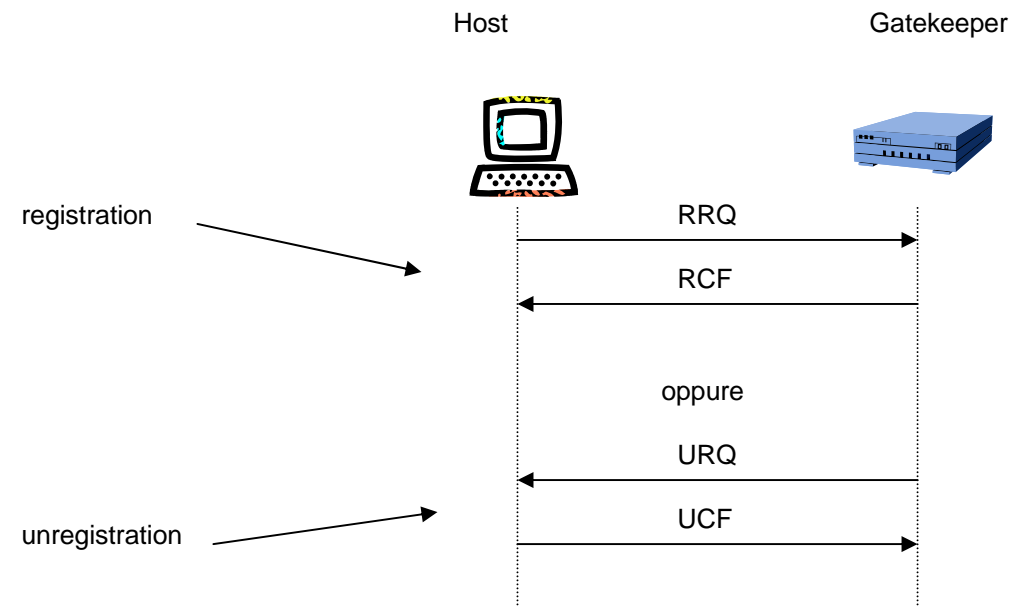

Admission

- The endpoint requests the permission to participate to a call with the Admission ReQuest (AQR) message
- The endpoint specifies
 - Type of call (point-to-point or multiparty)
 - the partner (or the list of partners)
 - il call identifier (una stringa univoca)
 - The call reference
 - The required bandwidth (in 100 bit/s units)
 - ... Other parameters

Admission

- The gatekeeper's positive answer is communicated to the endpoint with the Admission ConFirmation (ACF) message
- In general the parameters in the ACF message are the same used in the ARQ message (parameter's values may be different)

Admission

- An important parameter in admission-related messages is the call model
- The endpoint can require
 - *direct call signaling*: exchanging call signaling directly with the remote partner
 - *gatekeeper-routed signaling*: exchanging call signaling with the gatekeeper
- The gatekeeper may confirm the terminal's request or force its decision on the call model to be used
- The gatekeeper rejects the request with the Admission ReJect (ARJ) message

Direct call signaling

- The figure shows a simple example of direct call signaling
- RAS signaling and call signaling are represented with a different thickness of lines
- In the figure, we assume that both endpoints are in the same zone

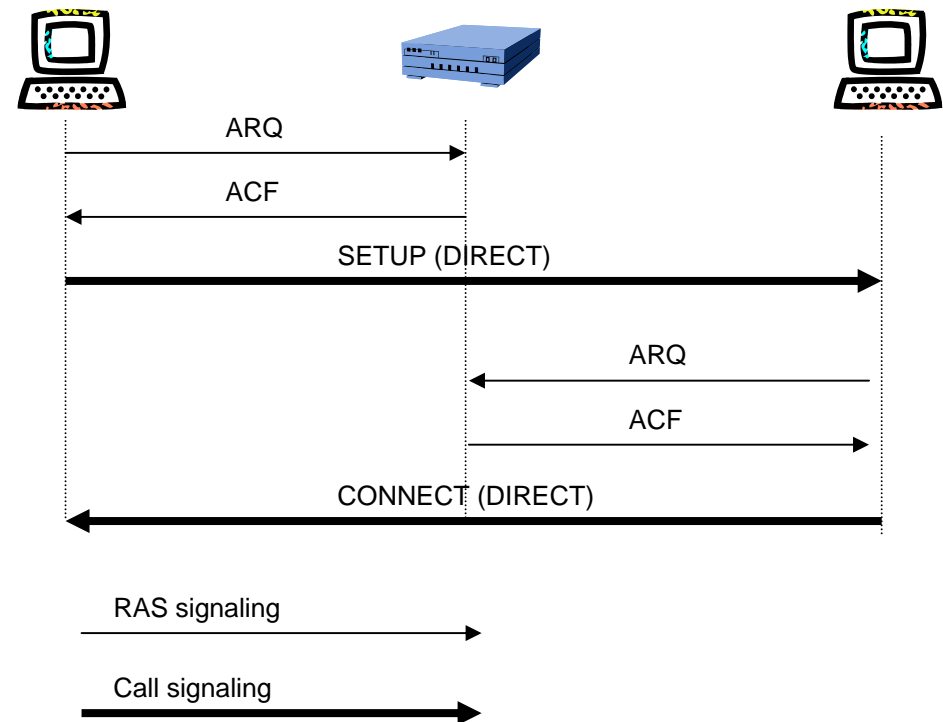

Gatekeeper-routed call signaling

- In the figure, we assume that both endpoints are in the same zone
- The gatekeeper routes call signaling

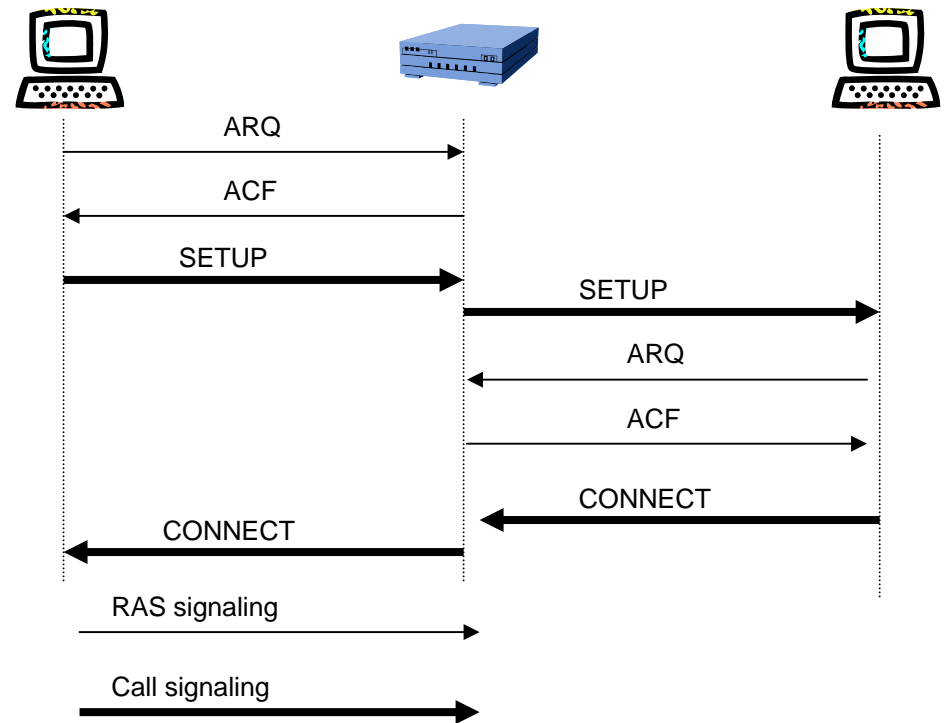

Disengage

- A Disengage ReQuest (DRQ) message is sent by the terminal to the gatekeeper to inform that the terminal is leaving a connection
- The DRQ message must specify the call reference, to identify the disengaged connection, and the disengage reason (for example, *normalDrop*, to signal a normal release of the connection without errors)

Disengage

- Normally, the gatekeeper responds with a Disengage ConFirm (DCF) message
- Only in case of error or inconsistency the gatekeeper responds with a Disengage ReJect (DRJ) message
 - An inconsistency case is that of a terminal erroneously sending to the wrong gatekeeper the DRQ message

Resource availability

- Two RAS messages concern resource availability: Resource Availability Indicate (RAI) and Resource Availability Confirm (RAC)
- RAI is sent by a gateway to a gatekeeper to communicate the amount of available resources
- The gatekeeper needing to forward a call through a gatekeeper can choose among multiple gateways taking into account available resources

H.255.0 call signaling messages (I)

- Alerting
- Call-proceeding
- Connect
- Progress
- Setup
- Setup Acknowledge
- Release Complete

H.255.0 call signaling messages (II)

- Information
- Notify
- Status
- Status Inquiry
- Facility

H.225.0 Call signaling Setup

- Setup
 - The SETUP message is used to start the call signalling transaction to setup a call
 - The SETUP message specifies, among other parameters
 - Identification of calling and called partners
 - Information on the logical channels to be used by H.245 control signalling to negotiate the format of media

H.225.0 Call signaling

Call-Proceeding

- Call-proceeding
 - The CALL-PROCEEDING message is a provisional response (optional) used to inform the receiver of the message that the issued request is being processed

H.225.0 Call signaling

Alerting

- Alerting
 - This message is used to inform the calling terminal that the called terminal has been reached and it is ringing

H.225.0 Call signaling Progress

- Progress
 - This is a provisional response issued by gateways (the function is similar to that of CALL-PROCEEDING)

H.225.0 Call signaling

Connect

- Connect
 - Message sent by the called terminal to inform that the the call has been accepted

H.225.0 Call signaling

Release complete

- Release complete
 - It is used to release a call



H.225.0 Call signaling Facility

- Facility
 - Used for the redirection of a call

H.245 control signaling

- H.245 is used for the negotiation of the format of media
- The H.245 signalling session can start after the reception of the SETUP message
- Various options are available
 - The called terminal can start the H.245 session after the reception of the SETUP message
 - The calling terminal can start the H.245 session after the reception of CALL PROCEEDING or PROGRESS or ALERTING
 - Otherwise, the H.245 session must start after the CONNECT message

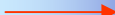
Base call without gatekeeper

-  **RAS signaling (H.255.0)**
-  **Call signaling (H.255.0)**
-  **Control signaling (H.245)**

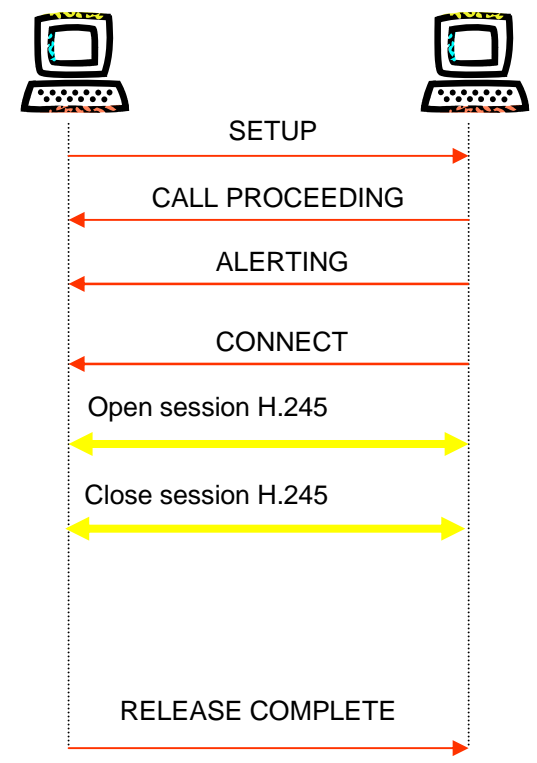

Base call with gatekeeper and direct endpoint call signaling

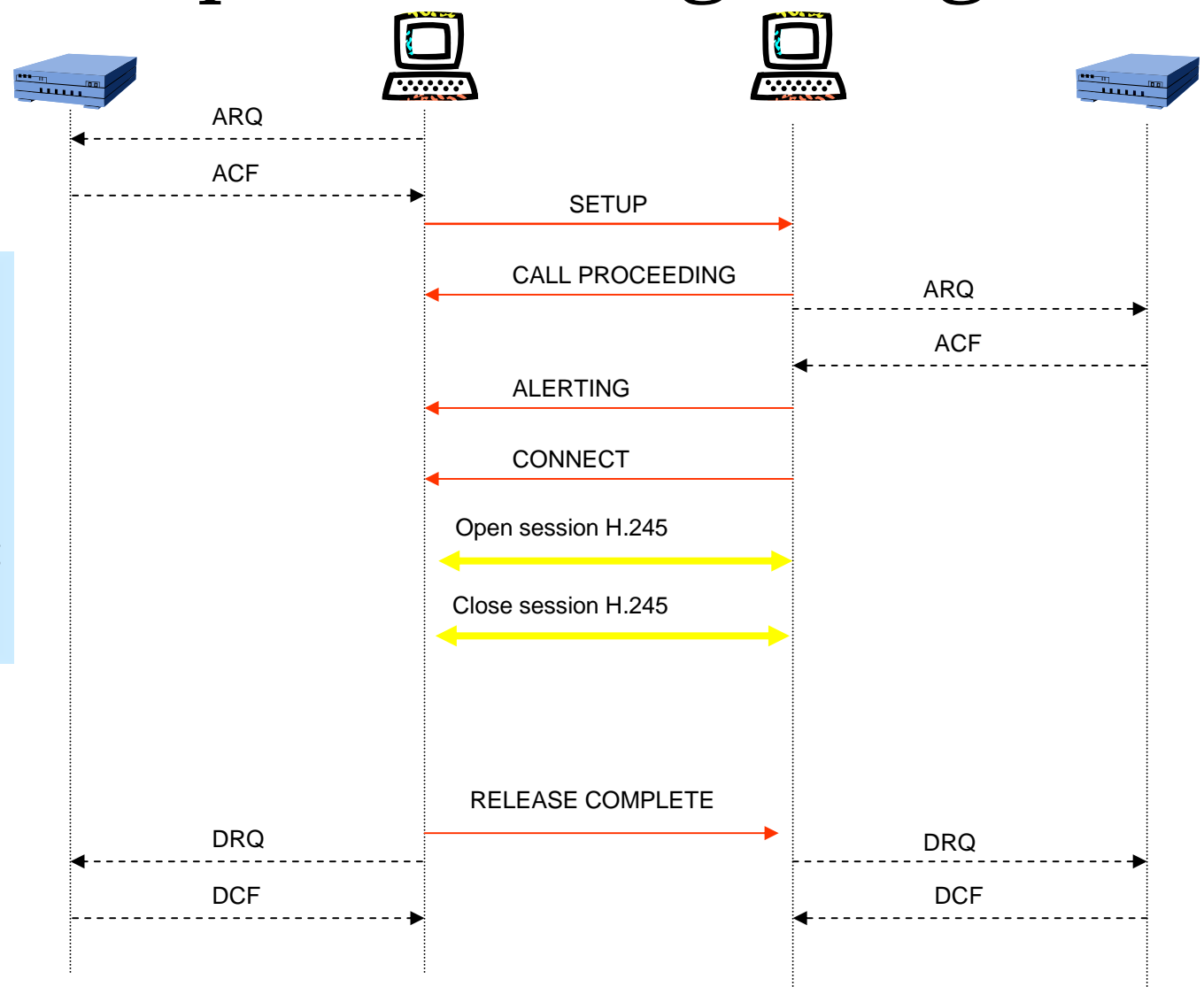

- RAS signaling (H.255.0)**
- Call signaling (H.255.0)**
- Control signaling (H.245)**

Base call with gatekeeper and direct routed call signaling

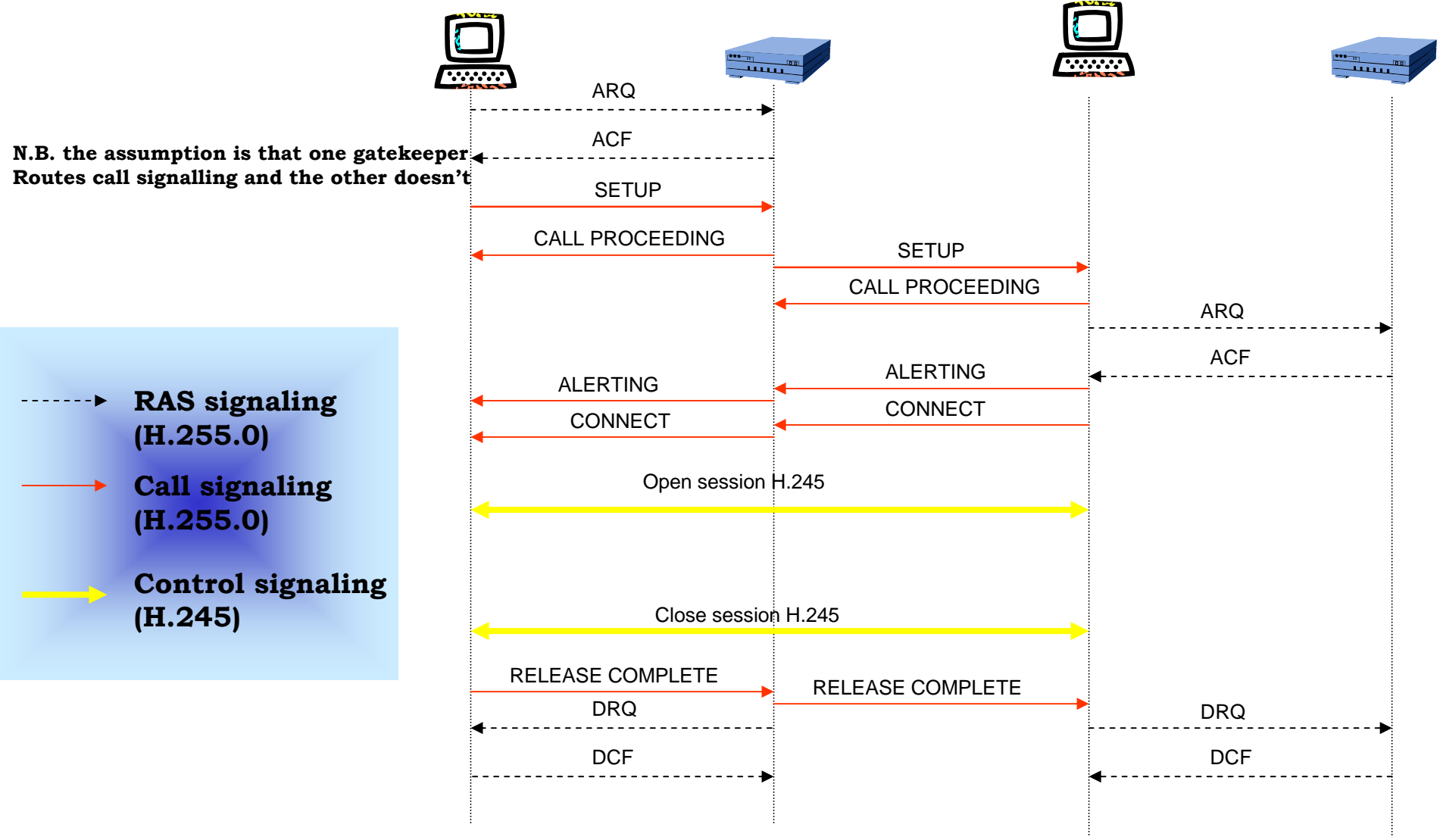

Base call gatekeeper routed call signaling

**GK2 rejects ARQ from EP2 because it wants to route call signaling.
 EP2 sends a FACILITY mess. to GK1.
 GK1**

-----> **RAS signaling (H.255.0)**
 -> **Call signaling (H.255.0)**
 -> **Control signaling (H.245)**

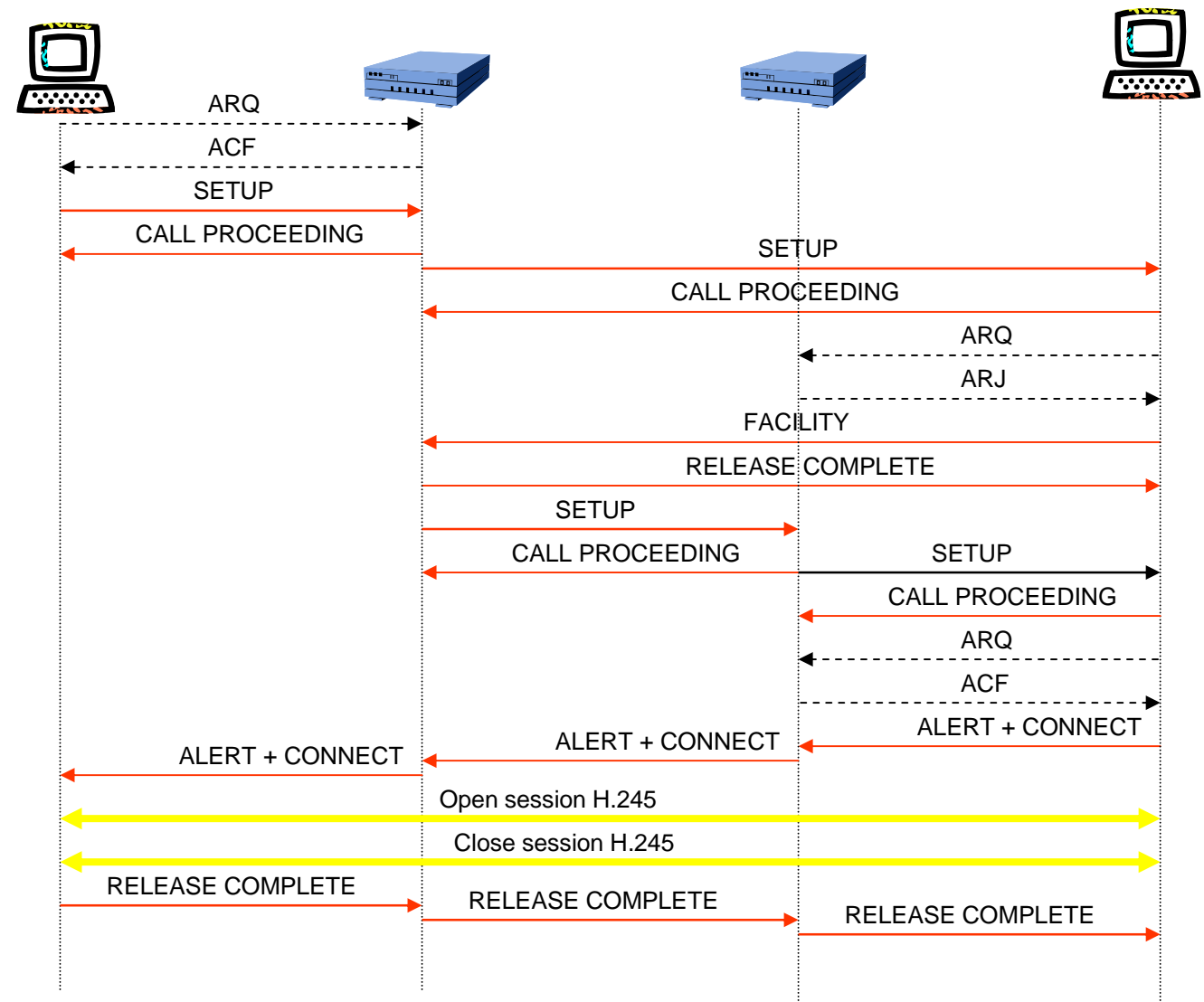

H.245: logical channels

- The H.245 control signaling establishes dedicated logical channels to transport media-related information
- To establish a logical channel two messages are required: **Open Logical Channel Message** and **Open Logical Channel Ack**
- Then, a **Capabilities Exchange** procedure is started, by which the two terminals exchange information about supported codecs and reach a decision about which codec/codecs is/are to be used

Connection (RAS, Call, Control)

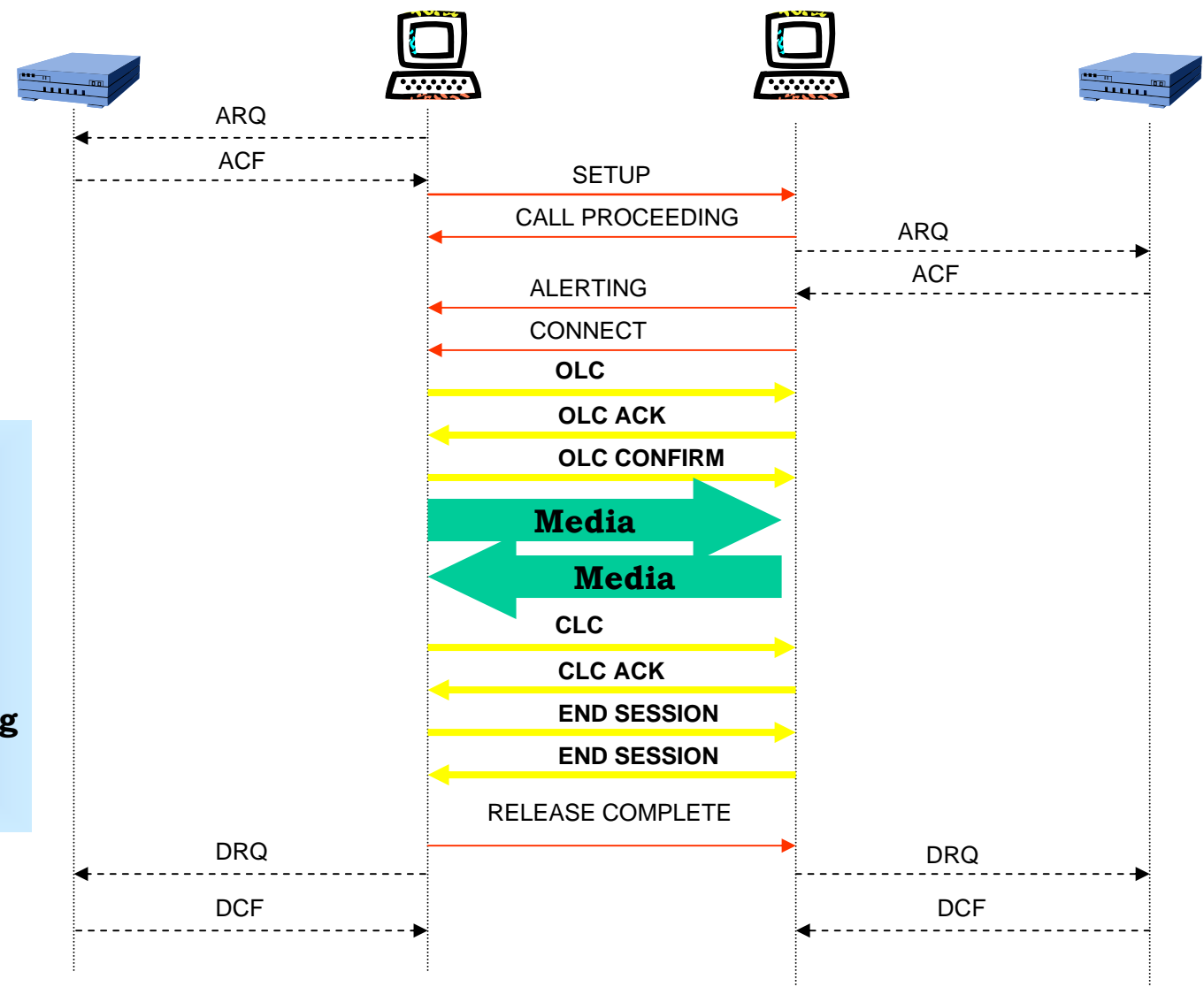

Legend for signaling types:

- > RAS signaling (H.255.0)
- > Call signaling (H.255.0)
- > Control signaling (H.245)

Media flow:

Media (green arrow pointing right)

Media (green arrow pointing left)